



RKDOORSYSTEMS

Let's make an entrance

ES2050 WIFI Keypad

The ES2050 keypad is designed for residential or light commercial use and offers multiple access options. With its slim design and choice of colours, the keypad is suitable for either frame or wall mounting, opening with fingerprint, keypad, key fob and connected with a WIFI app to offer remote opening and compatible voice control through Alexa devices.

Technical

- 📏 **Dimensions : 148 x 44 x 22mm**
- 🎨 **Colour : Silver or Black**
- 👤 **User capacity : 1000**
- ⚡ **Operating voltage : 12-18V DC**
- 🔑 **Opening functions : Mobile App, Finger print, Keypad, Key fob**
- 🔗 **Additional options : WIFI remote opening & Alexa voice activation**



Features & benefits

- ✓ Slimline design for wall or frame mounting
- ✓ High performance IP66 weather rating for all locations
- ✓ Multiple opening functions for residential & light commercial use
- ✓ Compatible with motorised locks and electronic day release latches
- ✓ Anti-vandal alloy construction in Silver or Black colours
- ✓ Fast installation with concealed fixings & 5m connection cable
- ✓ Built in doorbell with app notification
- ✓ User control with access viewing records
- ✓ Remote opening function via WIFI App
- ✓ Compatible with Alexa offering voice activation
- ✓ Up to 1000 users with add and delete user function via app
- ✓ One time entry code via app for remote access permission (5min code validity)



Wiring Diagrams

The following wiring diagrams are designed to offer a quick installation guide for connecting the keypad to an RKDS motorised lock or electronic day release latch. The keypad is supplied with numerous connection wires for additional access control elements and for ease of clarity, these have not been shown on the diagrams.

Please remember that all electrical installations should be undertaken by a qualified electrician only. All RK Door Systems electrical products are designed for connection via suitable transformers only and should never be directly connected to the mains supply. If in doubt please ask!

WIRING DIAGRAM - MOTORISED LOCK TYPES ES1200 & ES1760

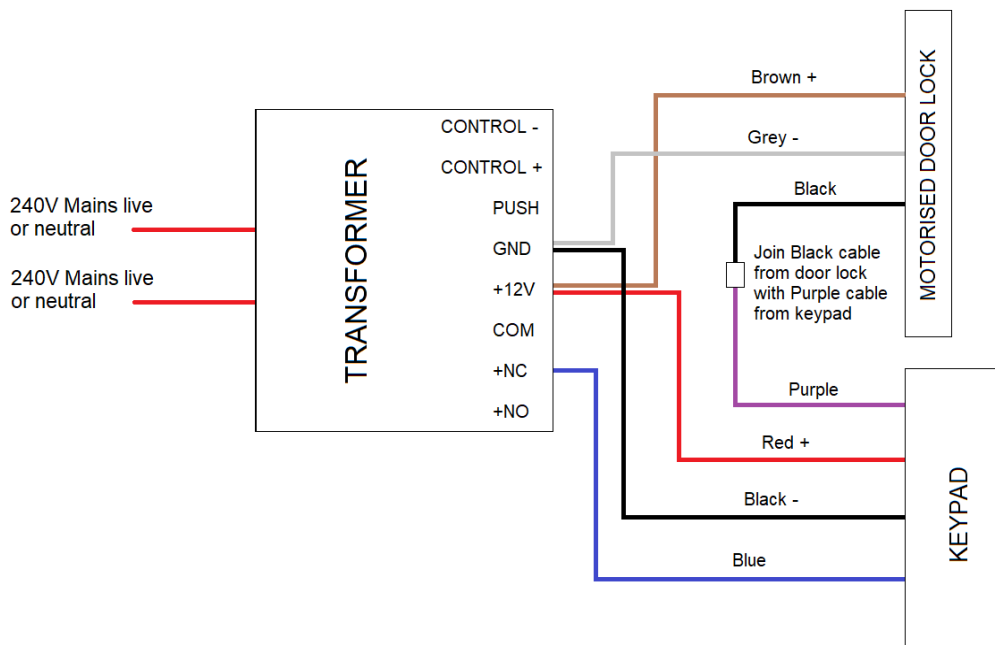

WIRING DIAGRAM - DAY RELEASE ES2100 & ES2110

